

Product **Polzahl: 2+PE, Kablestecker, Power, S-Kodierung, Kabeldurchlass 8-10 mm**
 Area **M12-S Series 814**
 Article number **99 0685 19 03**

Illustration

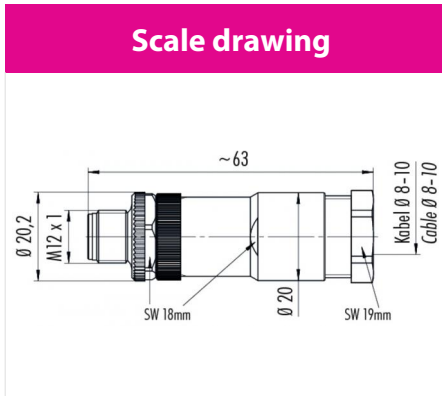

Scale drawing



Contact Arrangement

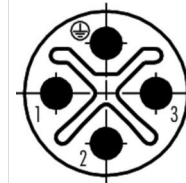

	X	Y
1	-2,55	0,00
2	0,00	-2,55
3	2,55	0,00
PE	0,00	2,55

Attenuation characteristics

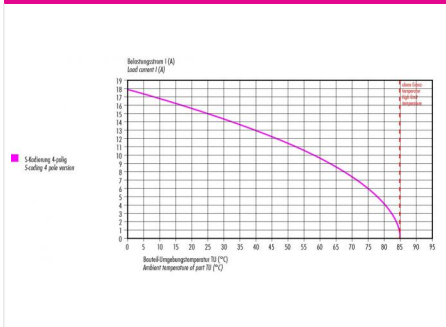

You can find the assembly instruction on the next page.

Technical data

General features

Connector Design Cable Connector
 Connector locking system bolted
 Termination removable screw
 Wire gauge (mm) max. 2,5 mm²
 Wire gauge (AWG) max. 14
 Cable outlet 8 - 10 mm
 Upper temperature 85 °C
 Lower temperature -40 °C

Cable data

Approval 1 UL

Electrical parameters

Rated voltage 630 V
 Rated impulse voltage 6000 V
 Pollution degree 3
 Overvoltage category III
 Material group III
 Rated current (40°C) 16 A
 Volume resistivity ≤ 3 mΩ
 Degree of protection IP67
 Mechanical operation > 50 Mating cycles

Material

Material of contact CuZn (Messing)
 Contact plating Au (gold)
 Material of contact body PA

Product	Polzahl: 2+PE, Kablestecker, Power, S-Kodierung, Kabeldurchlass 8-10 mm
Area	M12-S Series 814
Article number	99 0685 19 03

Installation instructions / Mounting cutout

