

Product sheet

Miniature connector



Product	Contacts: 24, Male angled connector, shieldable, cable outlet 4 – 6 mm, with UL approval	Area	M16 IP67 Series 423
Pole	24	Article number	99 5495 75 24

Illustration



Scale drawing

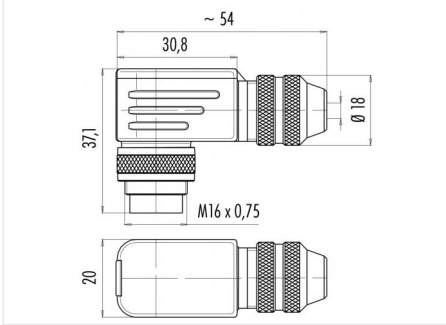

Contact Arrangement

	X	Y
1	4,00	-1,50
2	4,00	0,35
3	4,00	2,20
4	2,40	3,10
5	2,40	1,30
6	2,40	-0,55
7	2,40	-2,40
8	0,80	-3,30
9	0,80	-1,50
10	0,80	0,35
11	0,80	2,20
12	0,80	4,00
13	-0,80	3,10
14	-0,80	1,30
15	-0,80	-0,55
16	-0,80	-2,40
17	-2,40	-3,30
18	-2,40	-1,50
19	-2,40	0,35
20	-2,40	2,20
21	-2,40	4,00
22	-4,00	1,30
23	-4,00	-0,55
24	-4,00	-2,40

Attenuation characteristic

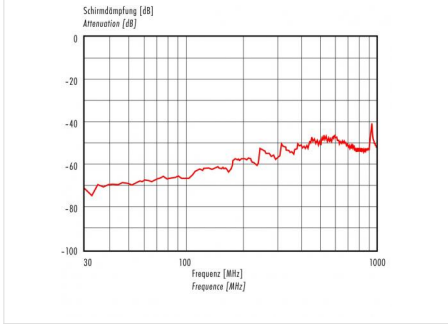

You can find the item description and assembly instruction on the next page.

Technical data

Common values

Connector Design	Male angled connector
Connector locking system	screw
Termination	Solder
Wire gauge (mm)	0.14 mm ²
Wire gauge (AWG)	26
Cable outlet	4 - 6 mm
Upper temperature	95 °C
Lower temperature	-40 °C

Electrical values

Rated voltage	60 V
Rated impulse voltage	500 V
Pollution degree	1
Overvoltage category	I
Material group	III
Rated current (40°C)	1 A
Volume resistivity	≤ 3 mΩ
EMV compliance	shielded
Degree of protection	IP67
Mechanical operation	> 500 mating cycles

Material

Material of contact	CuZn (Brass)
Contact plating	Au (Gold)
Material of contact body	PBT (UL 94 V-0)
Material of housing	CuZn (Brass nickel-plated)

Contacts: 24, Male angled connector, shieldable, cable outlet 4 – 6 mm, gold plated contacts, with UL approval

Product

Contacts: 24, Male angled connector, shieldable, cable outlet 4 – 6 mm, with UL approval 24

Area
Article number

**M16 IP67 Series 423
99 5495 75 24**

Pole

Item description

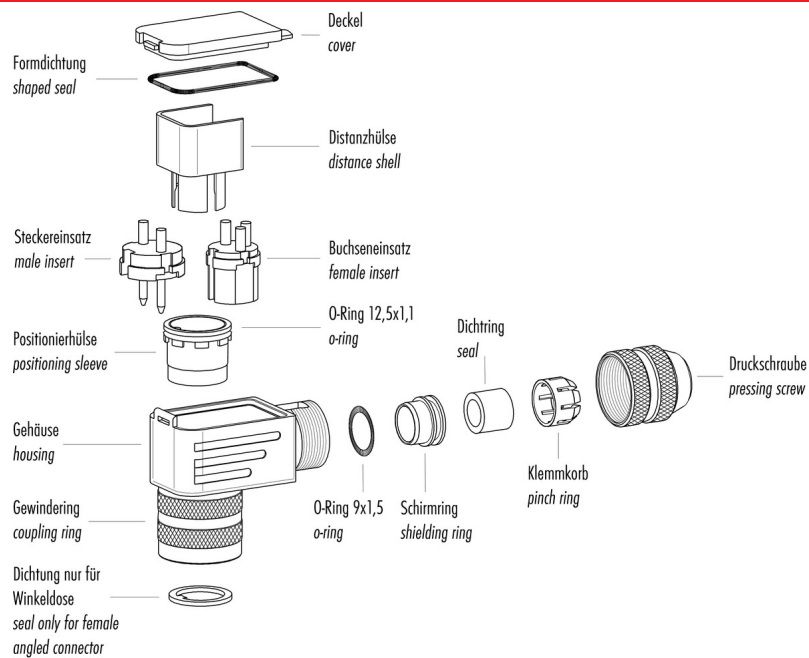

Installation instructions / Mounting cutout

Winkelversion

1. Dichtungen montieren (3x).
2. Kabelteile auffädeln.
3. Kabel und Schirm abmanteln.
4. Litzen durch das Gehäuse fädeln.
5. Schirmring, Klemmkorb montieren.
6. Druckschraube leicht andrehen.
7. Litzen an Kontakteinsatz löten.
8. Verdrehhülse in Winkelstellung montieren.
9. Kontakteinsatz, Distanzhülse einsetzen.
10. Deckel einhaken.
11. Druckschraube festziehen (ca. 10-20 Nm).

Angled version

1. Assemble sealing rings (3x).
2. Bead cable parts.
3. Dismantle cable and shielding braid.
4. Push single wires through housing.
5. Mount shielding ring and pinch ring.
6. Slightly fix pressing screw.
7. Solder wires to insert.
8. Mount positioning sleeve in angled position.
9. Put in insert and distance sleeve.
10. Mount lid.
11. Fix pressing screw (approx. 10-20 Nm).

