

Product	Contacts 3: Adaptor, female connector M8 - male connector M12	Area	Connecting cords Series 765
Pole	3	Article number	09 5280 00 03

Illustration

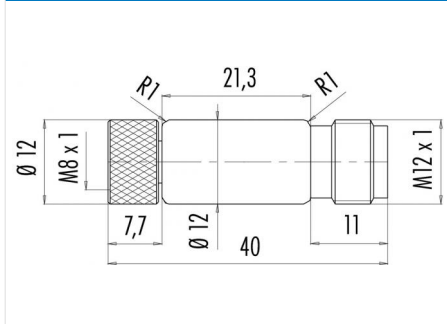

Scale drawing



Contact Arrangement

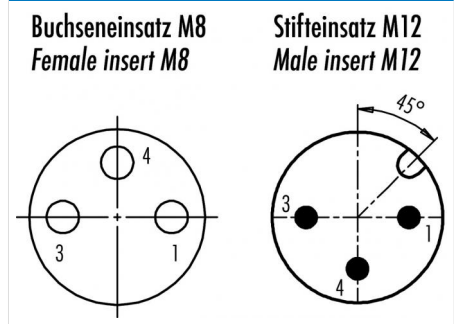

Technical data

Common values

Connector Design	Adaptor
Connector locking system	screw
Upper temperature	85 °C
Lower temperature	-25 °C

Electrical values

Rated voltage	60 V
Rated impulse voltage	1500 V
Pollution degree	3
Overvoltage category	II
Material group	II
Rated current (40°C)	4 A
Volume resistivity	≤ 3 mΩ
EMV compliance	not shielded
Degree of protection	IP67
Mechanical operation	> 100 mating cycles

Material

Material of contact	Pin/ CuZn (brass), socket/ CuSn (bronze)
Contact plating	Au (Gold)
Material of contact body	PUR
Material of housing	Hot-melt adhesive

Contacts 3: Adaptor, female connector M8 - male connector M12