

Product sheet

Output connector

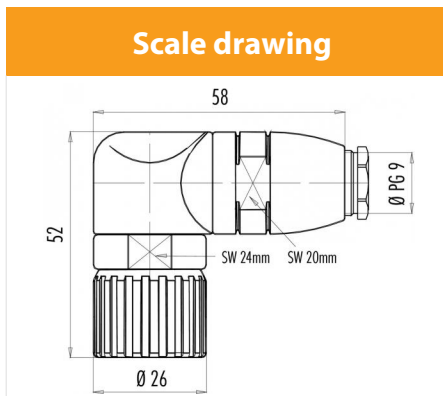

Product	Contacts: 19, Female angled connector, right-turning (the pin and socket insert counter-rotate in right and left turning models)	Area	M23 Power Series 623
Pole	19	Article number	99 4632 70 19



Contact Arrangement

	X	Y
1	-3,00	5,20
2	-5,20	3,00
3	-6,00	0,00
4	-5,20	-3,00
5	-3,00	-5,20
6	0,00	-6,00
7	3,00	-5,20
8	5,20	-3,00
9	6,00	0,00
10	5,20	3,00
11	3,00	5,20
12	0,00	6,00
13	-2,75	1,60
14	-2,75	-1,60
15	0,00	-3,00
16	2,75	-1,60
17	2,75	1,60
18	0,00	3,00
19	0,00	0,00

You can find the assembly instruction on the next page.

Technical data

Common values

Connector Design	Female angled connector
Connector locking system	screw
Termination	Solder
Wire gauge (mm)	16x1.0/ 3x1.5 mm ²
Wire gauge (AWG)	16x18/ 3x16
Cable outlet	6 - 10 mm
Upper temperature	125 °C
Lower temperature	-20 °C

Electrical values

Rated voltage	150 V
Rated impulse voltage	1500 V
Pollution degree	3
Overvoltage category	II
Material group	III
Rated current (40°C)	16x8A/ 3x10A
Volume resistivity	≤ 3 mΩ
EMV compliance	not shielded
Degree of protection	IP67
Mechanical operation	> 50 mating cycles

Material

Material of contact	CuSn (Bronze)
Contact plating	Au (Gold)
Material of contact body	PBT/PA66
Material of housing	CuZn (Brass nickel-plated)

Contacts: 19, Female angled connector, right-turning

Product

Contacts: 19, Female angled connector, right-turning (the pin and socket insert counter-rotate in right and left turning models)

Area
Article number

**M23 Power Series 623
99 4632 70 19**

Pole

19

Installation instructions / Mounting cutout

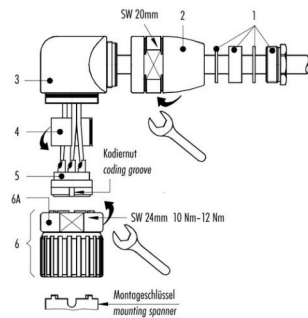

- Kabelverschraubung Pos. 1, Adapter Pos. 2 und Winkelkörper Pos. 3 auf das Kabel schieben.
- Kabel-Außenmantel 30 mm absolieren.
- Folie, Füller und innere Isolierungen abschneiden.
- Litzen 3,5 mm absolieren, verdrehen und verzinnen.
- Litzen an Kontakte löten, crimpen oder schrauben.
- Distanzhülse Pos. 4 einfügen.
- Einsatz Pos. 5 und Distanzhülse Pos. 4 in Einheit Pos. 6 einführen. Hierbei ist zu beachten, daß die gewünschte Kodiernut des Einsatzes Pos. 5 in den Kodiersteg eingeführt wird.
- Gesamte Einheit in Winkelkörper einführen (Achtung: acht Kodiermöglichkeiten) und mit Mutter Pos. 6A sichern (Anzugsdrehmoment: 10 Nm bis 12 Nm).
- Adapter Pos. 2 Festschrauben auf Anschlag.
- Kabelverschraubung Pos. 1 Festschrauben.

- Anzugsdrehmoment für Klemmschraube Kontakteinsatz Pos. 5 mit Schraubkontakten beachten:
- max. 0,1 Nm für Schraubkontakte Steckdurchmesser 1 mm
 - max. 0,2 Nm für Schraubkontakte Steckdurchmesser 2 mm

- Push the cable screw connection (1), adapter (2) and angled housing (3) onto the cable.
- Strip the cable coating by 30 mm.
- Trim foil, filler and inner insulation.
- Strip the single wires by 3.5 mm, twist and tin.
- Solder, crimp or screw the single wires to the contacts.
- Insert the distance shell (4).
- Guide the insert (5) and distance shell (4) into the unit (6), mind that the desired coding groove of the insert (5) is pushed into the coding bar.
- Insert the entire unit into the angle housing (Attention: eight coding options) and secure with nut (6A) (torque: 10 Nm up to 12 Nm).
- Screw the adapter (2) as tight as possible.
- Screw the cable gland (1) as tight as possible.

- Please note: torque for clamping screw for contact insert (5) with screw contacts:
- max. 0.1 Nm for screw contacts with mating dia. 1 mm
 - max. 0.2 Nm for screw contacts with mating dia. 2 mm