

Product	Contacts 4/3: Double plug M12x1 - 2 female angled connectors, with LED PNP NOC, M12x1, 3 x 0.34 mm² PUR	Area	Connecting cords Series 765
Pole	4/3	Article number	79 5202 10 04

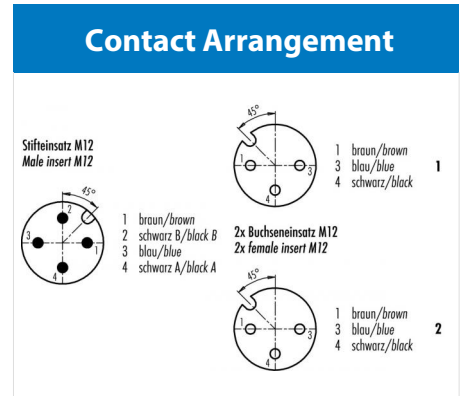
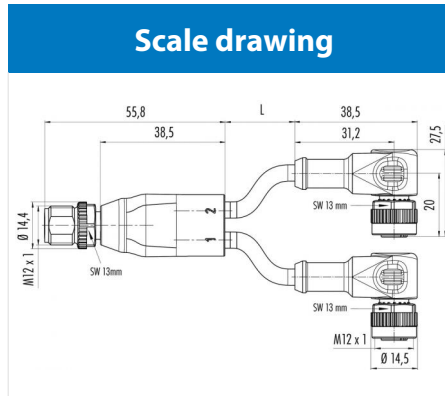

Technical data

Common values

Connector Design	Double plug - female angled connector
Connector locking system	screw
Termination	crimp, injection-moulded cable
Wire gauge (mm)	0.34 mm ²
Wire gauge (AWG)	22
Upper temperature	85 °C
Lower temperature	-25 °C

Electrical values

Rated voltage	30 V
Rated impulse voltage	500 V
Pollution degree	3
Overvoltage category	II
Material group	II
Rated current (40°C)	4 A
Volume resistivity	≤ 3 mΩ
EMV compliance	not shielded
Degree of protection	IP68
Mechanical operation	> 100 mating cycles

Material

Material of contact	Pin/ CuZn (brass), socket/ CuSn (bronze)
Contact plating	Au (Gold)
Material of contact body	PUR
Material of housing	PUR

Contacts 4/3: Connecting cord 1 m, double plug M12x1 - 2 female angled connectors M12x1, with LED PNP NOC, cable 3 x 0.34 mm² PUR