

1185/6185

Rev.

APPLICATION DRAWING

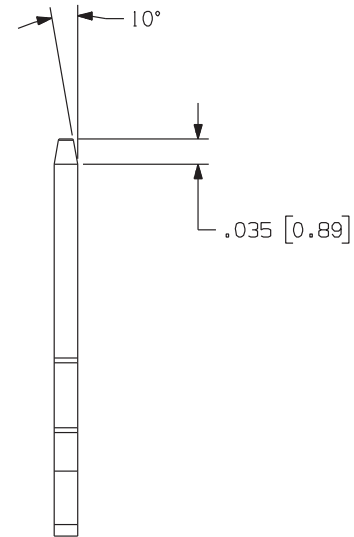
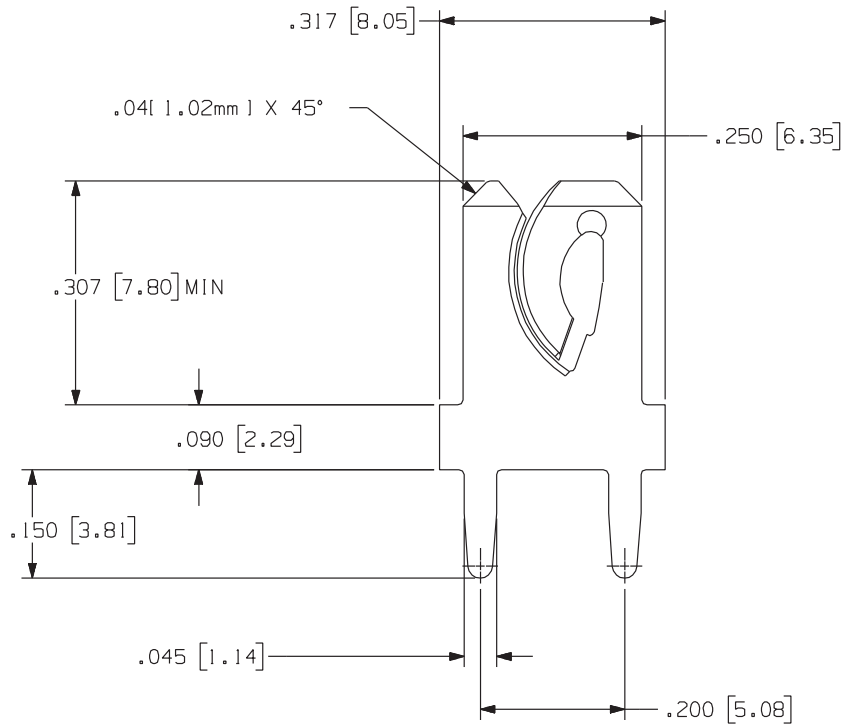
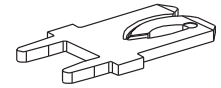

RoHS COMPLIANT

PART NUMBER	MATERIAL	FINISH
6185 [ REELED PART NUMBER ]	.032 [ 0.81mm ] BRASS	100% MATTE TIN OVER COPPER
1185	.032 [ 0.81mm ] BRASS	100% MATTE TIN OVER COPPER

Zierick Product Related Recommendations are general guidelines only. Since each customer's design, process and application is different it is necessary that customers thoroughly test our products in specific applications.

**ZIERICK**

Radio Circle Drive  
Mount Kisco, New York 10549

.250 X .032 IDC TAB

THIS DOCUMENT AND THE CONFIDENTIAL INFORMATION CONTAINED HERE ARE THE PROPERTY OF ZIERICK MANUFACTURING CORPORATION AND MAY NOT BE USED IN WHOLE OR IN PART IN ANY WAY, OR COMMUNICATED TO ANY PARTY OTHER THAN THE RECIPIENT WITHOUT THE EXPRESS PRIOR WRITTEN CONSENT OF ZIERICK MANUFACTURING CORPORATION.

1185/6185