

Product	Contacts: 4, Female angled connector, metal lock, screw terminal connection	Area	M12-A Series 713
Pole	4	Article number	99 0430 24 04

Illustration

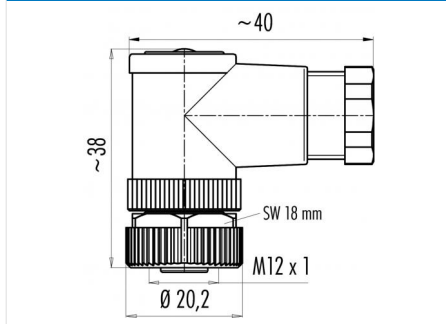

Scale drawing



Contact Arrangement

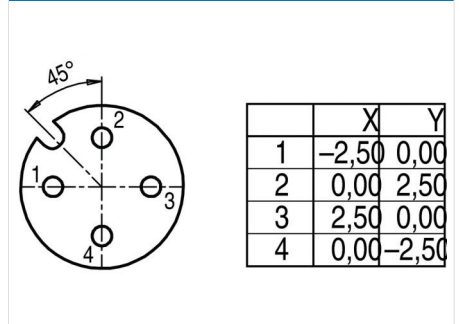

You can find the item description and assembly instruction on the next page.

Technical data

Common values

Connector Design	Female angled connector
Connector locking system	screw
Termination	Screwing
Wire gauge (mm)	0.75 mm ²
Wire gauge (AWG)	18
Cable outlet	4 - 6 mm
Upper temperature	85 °C
Lower temperature	-40 °C

Electrical values

Rated voltage	250 V
Rated impulse voltage	2500 V
Pollution degree	3
Overvoltage category	II
Material group	II
Rated current (40°C)	4 A
Volume resistivity	≤ 8 mΩ
EMV compliance	nicht geschirmt
Degree of protection	IP67
Mechanical operation	> 50 mating cycles

Material

Material of contact	CuZn (Brass)
Contact plating	CuSnZn (Optaloy)
Material of contact body	PA
Material of housing	PBT

Contacts: 4, Cable outlet: 4-6 mm, female angled connector, metal lock, screw terminal connection, with UL approval

Product	Contacts: 4, Female angled connector, metal lock, screw terminal connection	Area	M12-A Series 713
Pole	4	Article number	99 0430 24 04

Item description

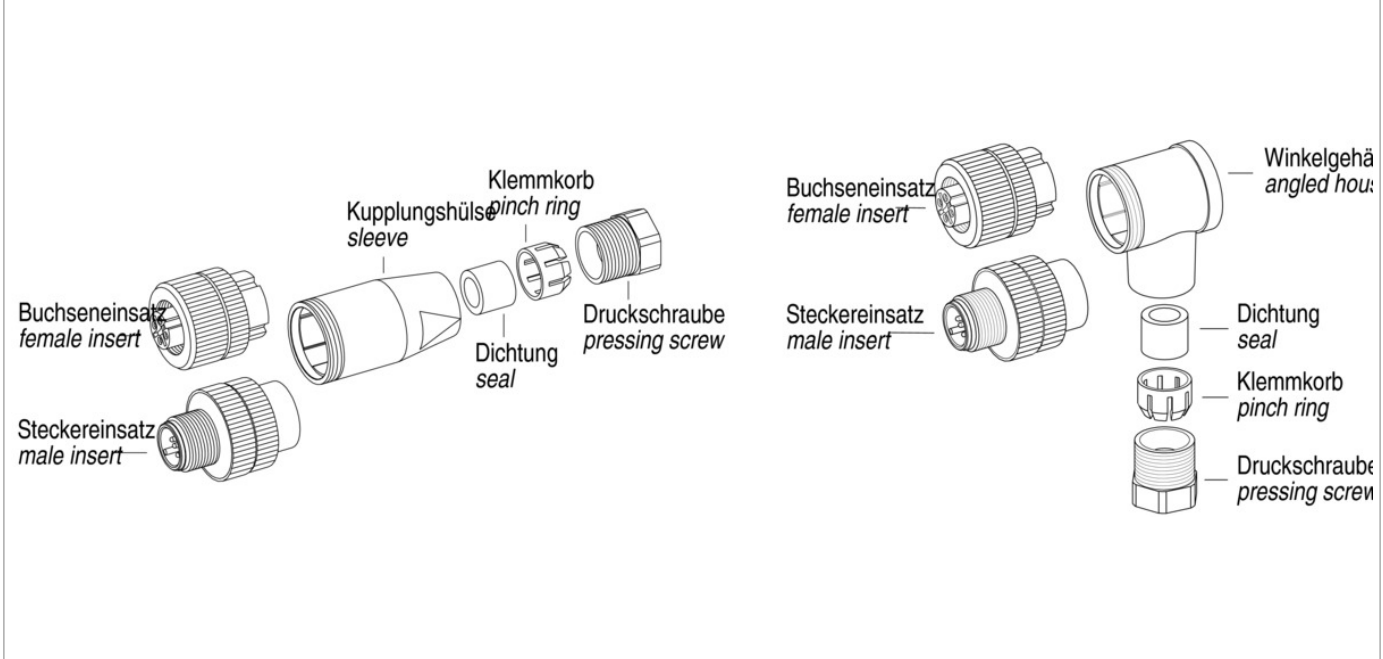

Installation instructions / Mounting cutout

