

Product sheet

Miniature connector



Product	Contacts: 19, Female cable connector, shieldable	Area	Push-Pull IP67 Series 440
Pole	19	Article number	99 4842 00 19

Illustration	Scale drawing	Contact Arrangement																																																												
		<table border="1" style="margin-left: auto; margin-right: auto;"> <thead> <tr> <th></th> <th>X</th> <th>Y</th> </tr> </thead> <tbody> <tr><td>A</td><td>2,50</td><td>-4,00</td></tr> <tr><td>B</td><td>4,00</td><td>-2,25</td></tr> <tr><td>C</td><td>4,25</td><td>0,00</td></tr> <tr><td>D</td><td>4,00</td><td>2,40</td></tr> <tr><td>E</td><td>2,30</td><td>4,00</td></tr> <tr><td>F</td><td>0,00</td><td>4,25</td></tr> <tr><td>G</td><td>-2,30</td><td>4,00</td></tr> <tr><td>H</td><td>-4,00</td><td>2,40</td></tr> <tr><td>I</td><td>-4,25</td><td>0,00</td></tr> <tr><td>K</td><td>-4,00</td><td>-2,25</td></tr> <tr><td>L</td><td>-2,50</td><td>-4,00</td></tr> <tr><td>M</td><td>0,95</td><td>-2,40</td></tr> <tr><td>N</td><td>2,40</td><td>-0,95</td></tr> <tr><td>O</td><td>2,40</td><td>0,95</td></tr> <tr><td>P</td><td>0,95</td><td>2,40</td></tr> <tr><td>R</td><td>-0,95</td><td>2,40</td></tr> <tr><td>S</td><td>-2,40</td><td>0,95</td></tr> <tr><td>T</td><td>-2,40</td><td>-0,95</td></tr> <tr><td>U</td><td>-0,95</td><td>-2,40</td></tr> </tbody> </table>		X	Y	A	2,50	-4,00	B	4,00	-2,25	C	4,25	0,00	D	4,00	2,40	E	2,30	4,00	F	0,00	4,25	G	-2,30	4,00	H	-4,00	2,40	I	-4,25	0,00	K	-4,00	-2,25	L	-2,50	-4,00	M	0,95	-2,40	N	2,40	-0,95	O	2,40	0,95	P	0,95	2,40	R	-0,95	2,40	S	-2,40	0,95	T	-2,40	-0,95	U	-0,95	-2,40
	X	Y																																																												
A	2,50	-4,00																																																												
B	4,00	-2,25																																																												
C	4,25	0,00																																																												
D	4,00	2,40																																																												
E	2,30	4,00																																																												
F	0,00	4,25																																																												
G	-2,30	4,00																																																												
H	-4,00	2,40																																																												
I	-4,25	0,00																																																												
K	-4,00	-2,25																																																												
L	-2,50	-4,00																																																												
M	0,95	-2,40																																																												
N	2,40	-0,95																																																												
O	2,40	0,95																																																												
P	0,95	2,40																																																												
R	-0,95	2,40																																																												
S	-2,40	0,95																																																												
T	-2,40	-0,95																																																												
U	-0,95	-2,40																																																												

You can find the item description and assembly instruction on the next page.

Technical data

Common values

Connector Design	Female cable connector
Connector locking system	Push-Pull
Termination	Solder
Wire gauge (mm)	0.25 mm ²
Wire gauge (AWG)	24
Cable outlet	4 - 8 mm
Upper temperature	85 °C
Lower temperature	-40 °C

Electrical values

Rated voltage	60 V
Rated impulse voltage	500 V
Pollution degree	1
Overvoltage category	I
Material group	III
Rated current (40°C)	3 A
Volume resistivity	≤ 3 mΩ
EMV compliance	shielded
Degree of protection	IP67
Mechanical operation	> 1000 mating cycles

Material

Material of contact	CuSn (Bronze)
Contact plating	Au (Gold)
Material of contact body	PBT (UL 94 V-0)
Material of housing	PA GF 25 (UL 94 V-0)

Contacts: 19, Female cable connector, shieldable

Product	Contacts: 19, Female cable connector, shieldable	Area	Push-Pull IP67 Series 440
Pole	19	Article number	99 4842 00 19

Item description

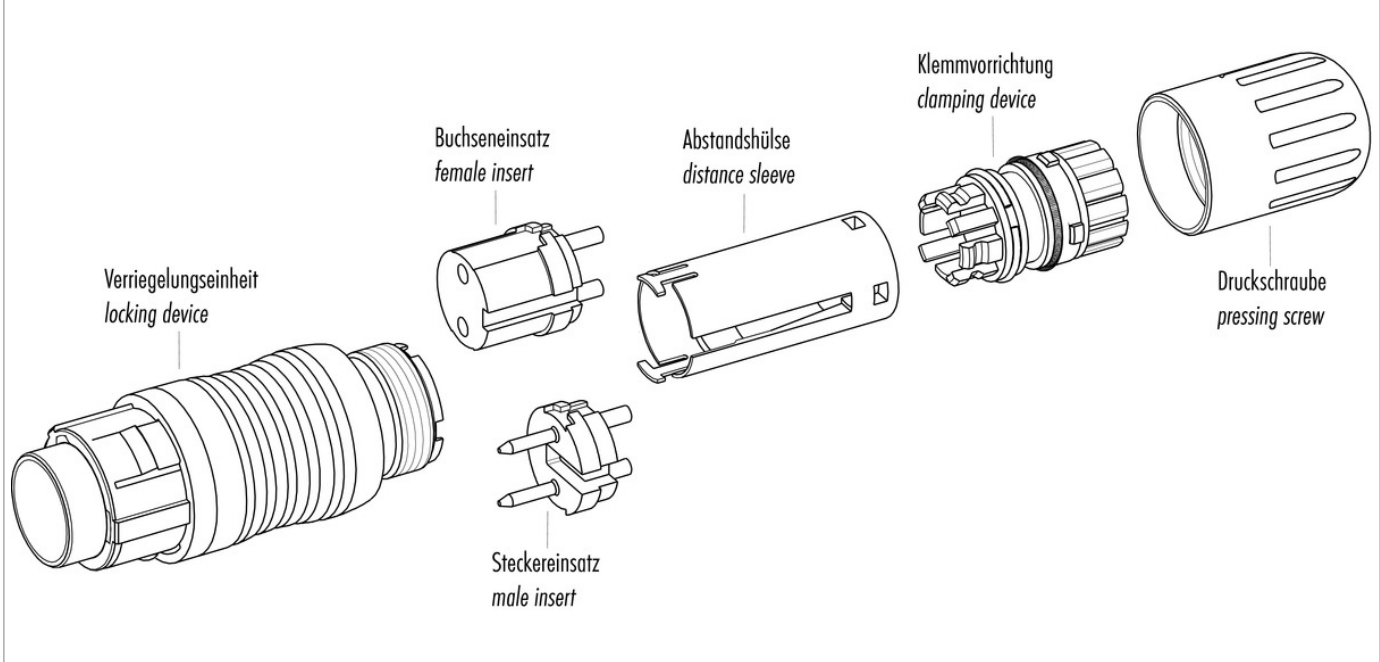

Installation instructions / Mounting cutout

1. Abmontein auf L = 33mm.
Ummantelung nicht abstreifen.
2. Druckschraube und Klemmvorrichtung aufziehen. Ummanntelung entfernen.
3. Litzen abschleifen und verzinnen.
4. Abschirmung aufwickeln und ausklemmen. Die Abschirmlitzen in der Krone rundum einführen.
5. Abstandshülse und Klemmvorrichtung vorstecken.
6. Gesteckte Einheit nach hinten übers Kabel schieben (ca. 10mm).
7. Einlötlitze anlöten.
8. Gesteckte Einheit nach vorne schieben bis sie in den Steckereinsatz einrastet.
9. Abschirmlitzen in Richtung Abschirmung abschleifen und kürzen.
zu lang: Litzen auf Dichtung - undicht
zu kurz: kein Kontakt zu Wellenring
10. Montierte Einheit in Trichterhülse stecken und Druckschraube festziehen.

1. Strip to 33mm length but do not take off cable jacket.
2. Beed pressing screw and clamp device. Remove cable jacket.
3. Strip the insulation off the wires and tin them.
4. Fan shielding braid and comb out.
5. Lock distance sleeve and clamp device.
6. Push mated units backwards over cable (approx. 10mm).
7. Solder inserts.
8. Push mated units forward until snap-in to contact insert.
9. Strip wires towards shielding ring and shorten: too long: wires on sealing ring - not tight too short: no contact to wave washer
10. Push assembled unit into center sleeve and tighten pressing screw.