

Product sheet

Subminiature connector

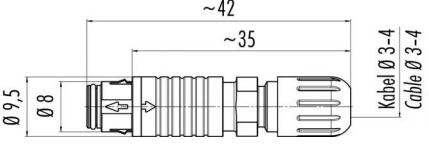
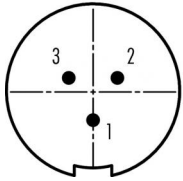

Product Pole	Contacts: 3, Cable plug connector 3	Area Article number	Micro Push-Pull IP67 Series 420 99 4705 00 03
--------------	---	---------------------	---

Illustration	Scale drawing	Contact Arrangement												
		 <table border="1" style="margin-left: 20px;"> <thead> <tr> <th></th> <th>X</th> <th>Y</th> </tr> </thead> <tbody> <tr> <td>1</td> <td>0,00</td> <td>-1,35</td> </tr> <tr> <td>2</td> <td>1,17</td> <td>0,68</td> </tr> <tr> <td>3</td> <td>-1,17</td> <td>0,68</td> </tr> </tbody> </table>		X	Y	1	0,00	-1,35	2	1,17	0,68	3	-1,17	0,68
	X	Y												
1	0,00	-1,35												
2	1,17	0,68												
3	-1,17	0,68												

You can find the item description and assembly instruction on the next page.

Technical data

Common values

Connector Design	Cable plug connector
Connector locking system	Micro Push-Pull
Termination	Solder
Wire gauge (mm)	0.14 mm ²
Wire gauge (AWG)	26
Cable outlet	3 - 4 mm
Upper temperature	80 °C
Lower temperature	-40 °C

Cable data

material housing	-
Insulation single lead	-
Single lead structure	-
Conductor resistance	-

Electrical values

Rated voltage	125 V
Rated impulse voltage	1500 V
Pollution degree	2
Overvoltage category	II
Material group	II
Rated current (40°C)	1 A
Volume resistivity	≤ 8 mΩ
EMV compliance	not shieldable
Degree of protection	IP67
Mechanical operation	> 1000 mating cycles

Material

Material of contact	CuZn (Brass)
Contact plating	Au (Gold)
Material of contact body	PA
Material of housing	PA

Contacts: 3, Cable plug connector

Product
Pole

Contacts: 3, Cable plug connector
3

Area
Article number

Micro Push-Pull IP67 Series 420
99 4705 00 03

Item description

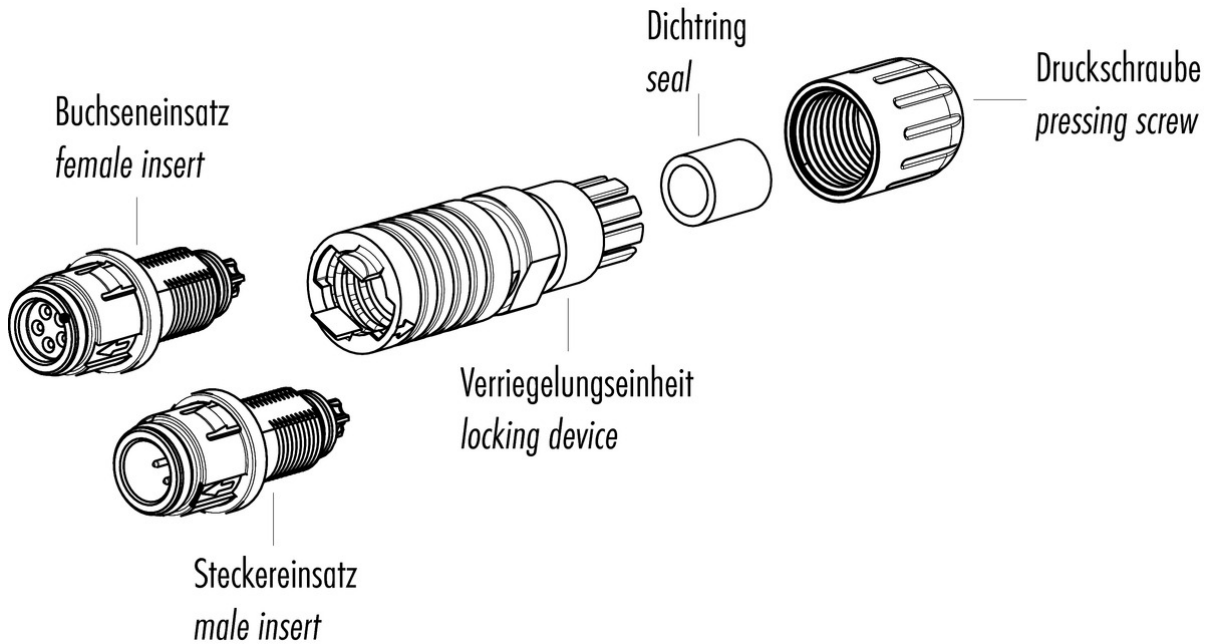

Installation instructions / Mounting cutout

1. Abmanteln auf $l = 9\text{mm}$.
Ummantlung abstreifen.
2. Dichtring in Klemmrichtung montieren.
Druckschraube und Verriegelungseinheit auf Kabel aufhängen.
3. Litzen abisolieren ($l = 3\text{mm}$) und verzinnen.
4. Einsätze anlöten.
5. Verriegelungseinheit orientiert, Pfeilrichtung beachten, aufschieben und aufschrauben.
6. Druckschraube aufschieben und vor dem Festziehen an Schlüsselfläche kontern.

(Bei Demontage zuerst Druckschraube öffnen)

1. Strip to 9mm length and remove cable jacket.
2. Mount sealing ring to clamp device to cable.
Bead pressing screw and clamp device.
3. Strip the insulation off the wires ($l = 3\text{mm}$) and tin them.
4. Solder wires to solder cups.
5. Align locking unit, bear in mind direction of arrow, push forward and screw tightly.
6. Push pressing screw forward and secure them at flats.

(Before unmounting first open pressing screw.)

