

Product	Contacts: 4, Dual plug connector, metal lock, screw terminal connection, Optimal contact plating, with UL approval	Area	M12-A Series 713
Pole	4	Article number	99 0429 186 04

Illustration	Scale drawing	Contact Arrangement															
		<table border="1"> <thead> <tr> <th></th> <th>X</th> <th>Y</th> </tr> </thead> <tbody> <tr> <td>1</td> <td>2,50</td> <td>0,00</td> </tr> <tr> <td>2</td> <td>0,00</td> <td>2,50</td> </tr> <tr> <td>3</td> <td>-2,50</td> <td>0,00</td> </tr> <tr> <td>4</td> <td>0,00</td> <td>-2,50</td> </tr> </tbody> </table>		X	Y	1	2,50	0,00	2	0,00	2,50	3	-2,50	0,00	4	0,00	-2,50
	X	Y															
1	2,50	0,00															
2	0,00	2,50															
3	-2,50	0,00															
4	0,00	-2,50															

You can find the item description and assembly instruction on the next page.

Technical data

Common values

Connector Design	Cable plug connector
Connector locking system	screw
Termination	Screwing
Wire gauge (mm)	0.75 mm ²
Wire gauge (AWG)	18
Upper temperature	85 °C
Lower temperature	-40 °C

Electrical values

Rated voltage	250 V
Rated impulse voltage	2500 V
Pollution degree	3
Overvoltage category	II
Material group	III
Rated current (40°C)	4 A
Volume resistivity	≤ 8 mΩ
EMV compliance	not shielded
Degree of protection	IP67
Mechanical operation	> 50 mating cycles

Material

Material of contact	CuZn (Brass)
Contact plating	CuSnZn (Optaloy)
Material of contact body	PA
Material of housing	PA

Contacts: 4, Cable outlet: 2 Cables Ø 2.1-3 mm or Ø 4-5 mm, dual plug connector, metal lock, screw terminal connection, Optimal contact plating, with UL approval

Product	Contacts: 4, Dual plug connector, metal lock, screw terminal connection, Optimal contact plating, with UL approval	Area	M12-A Series 713
Pole	4	Article number	99 0429 186 04

Item description

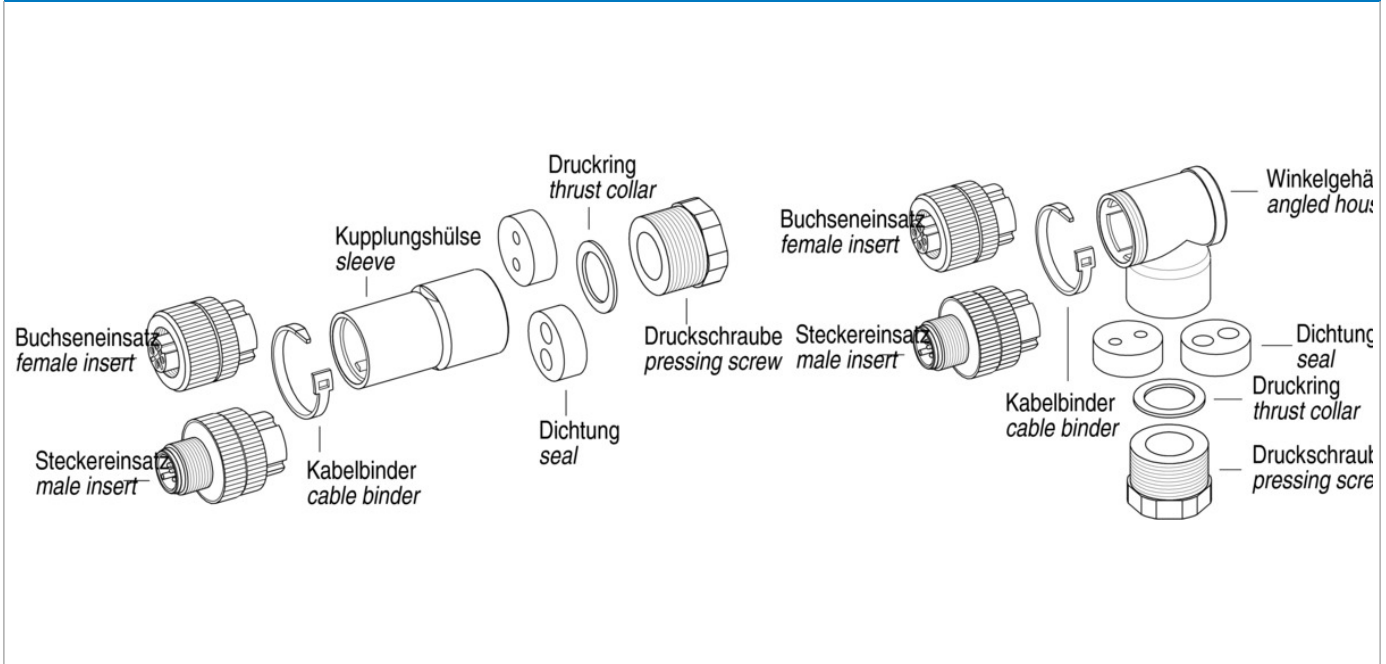

Installation instructions / Mounting cutout

